

# Hook clamps

- A gripping alternative -

**News!**  
02 / 2010

- ✓ **Economical**  
(optimal price/performance ratio )
- ✓ **Compact**
- ✓ **Easy to use**
- ✓ **100% compatible to current systems**
- ✓ **Operation via lever and/or hex key**
- ✓ **One or two hooks**
- ✓ **Hooks on right, left or both sides**



**Modular Fixturing Systems**



*Fixed on precision*

### NEW Compact “ECO” Hook Clamp

For many years Witte has been on the fixturing market with a comprehensive programme of different kinds of hook clamps. The clamps, enabling secure fixation of large surface car parts with round or slot holes in areas difficult to access, have been continuously developed and matched to the respective needs of our customers.

Next to dimensional variations Witte supplies an application orientated range with regard to models and operation.

New materials, combinations and manufacturing processes have been incorporated into our latest hook clamp Compact “ECO”. Light materials such as aluminium alloys, reduction of single and wear parts, design changes and function integration make Compact “ECO” an indispensable, high performance fixture component in modern automotive body fixturing.

Of course all of our previous models of hook clamps are still available including latest modifications, which fulfill not only technical but also price requirements.

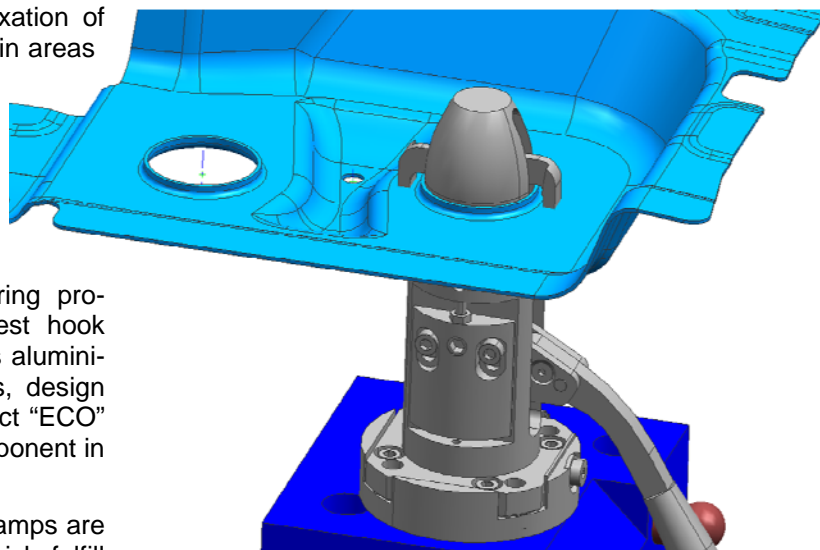

### Flexibility is a “MUST” at Witte!

Almost every kind of hook clamp, whichever version, must be adapted to sheet metal parameters. The data required to customize hook clamps is described on opposite page. Please forward your specific data for a qualified technical quotation.

Pricing is very simple, just like our technical solutions. Independent of pin or ring size all hook clamps of one version have the same price.

### NEW Rotation and shim unit for hook clamps

- ✓ Shim possibility in X, Y und Z  $\pm 1$ mm
- ✓ Position of hook clamp unit can be rotated 360° independent of hook clamp base
- ✓ Can be retrofitted, fits all hook clamps

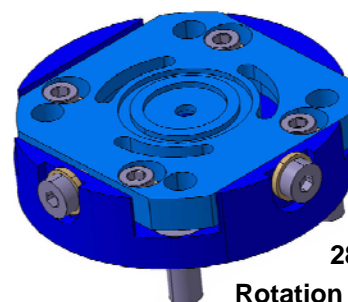

281407

Rotation and shim unit for hook clamps



EN 9100:2003

Zertifikat: 01 117 058346



DIN EN ISO 9001:2000

Zertifikat: 01 100 042211

Subject to technical changes.

Subject to printing errors and mistakes.

#### Certifications

Witte Barskamp GmbH & Co. KG is DIN-certified

- DIN EN ISO 9001
- DIN EN ISO 9100
- QSF-A (Luft- und Raumfahrt Zulieferer)



**NEW** Compact „Eco“



Compact „Classic“



Compact „Exzenter“



Compact „Mini“

## Technical data

	Compact "Eco"	Compact "Classic"	Compact "Exzenter"	Compact "Mini"
Total height	159 mm	159 mm	159 mm	129 mm
Set up height	110 mm	110 mm	110 mm	80 mm
Base diameter	Ø80 mm	Ø80 mm	Ø80 mm	Ø80 mm
Total diameter for connection holes	Ø65 mm / für M8	Ø65 mm / für M8	Ø65 mm / für M8	Ø65 mm / für M8
For metal thickness	0-5 mm	0-5 mm	0-5 mm	0-5 mm
Pin diameter	15-40 mm	15-40 mm	15-40 mm	15-40 mm
Top ring diameter/height	Ø50 mm / 13 mm	Ø50 mm / 13 mm	Ø50 mm / 13 mm	Ø50 mm / 13 mm
Hook clamp force (Z-direction)	ca. 1000 N	ca. 1000 N	ca. 1000 N	700 N
Operating force lever	ca. 30 N	ca. 30 N	ca. 30 N	✗
Operating force drive / WAF	5 Nm / WAF5	5 Nm / WAF15	✗	0,5 Nm / WAF5
Rotating operating lever <sup>1</sup>	✓ on request	✓	✗	✗
Article number in silver	281416	82442	90894	280581
Article number in black	281416-1	82442-1	90894-1	280581-1

<sup>1</sup> Avoidance of workpiece collisions/optimal accident protection

## Individual configuration

### Hole contour

Nominal diameter  $D_N$

Tolerance T of pin

Height of raised edge h

Sheet metal thickness t

Radius R

Length of slot L

Version

Round hole

Slot hole

\_\_\_\_\_ mm

\_\_\_\_\_ mm

\_\_\_\_\_ mm

\_\_\_\_\_ mm

\_\_\_\_\_ mm

\_\_\_\_\_ mm

Single hook

Double hook

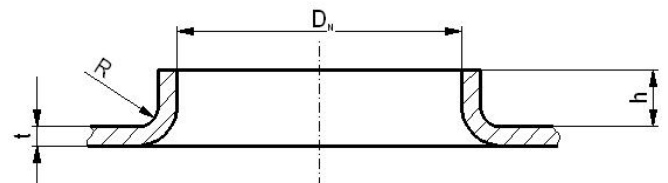
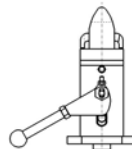
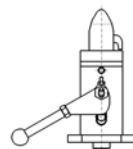

## Accessories (Optional)

	Compact "Eco"	Compact "Classic"	Compact "Exzenter"	Compact "Mini"
Joint power drill	✗	✗	✗	✓
Rotation and shim unit for hook clamps	✓	✓	✓	✓
Hook key	✗	✗	✓	✗

# Is something special required?

## Hook clamps with spring loaded hooks



- ✓ Predefined hook clamping force (protects part and avoids pressure points)
- ✓ Pre-selection of clamping force with 90N, 180N standard, 360N
- ✓ Hook direction and clamping lever can both be rotated by 360° independent of base plate and hook direction (best possible positioning to avoid collision with part)

## Mechanical hook clamps with spring loaded center pin

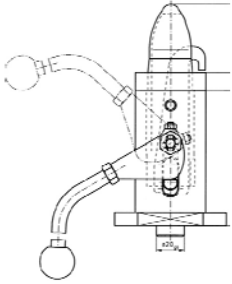

- ✓ Model identical to Classic hook clamp with one or two hooks
- ✓ Self centering with spring loaded conical centre pin
- ✓ Suitable for holes with up to approx. 2mm difference in diameter i.e. 28-30mm

## Autocenter hook clamps

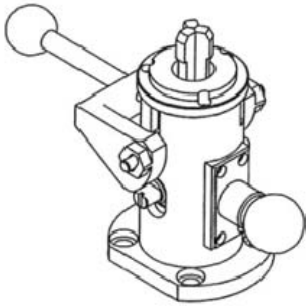

- ✓ Supports workpiece through hole
- ✓ Centers it through outward radial movement of three hooks at 120°
- ✓ Clamps using lever

## Pneumatic or hydraulic operated hook clamps

- ✓ Witte also offers special customized hook clamp solutions incorporating operation via manual or CNC controlled pneumatic or hydraulic systems.

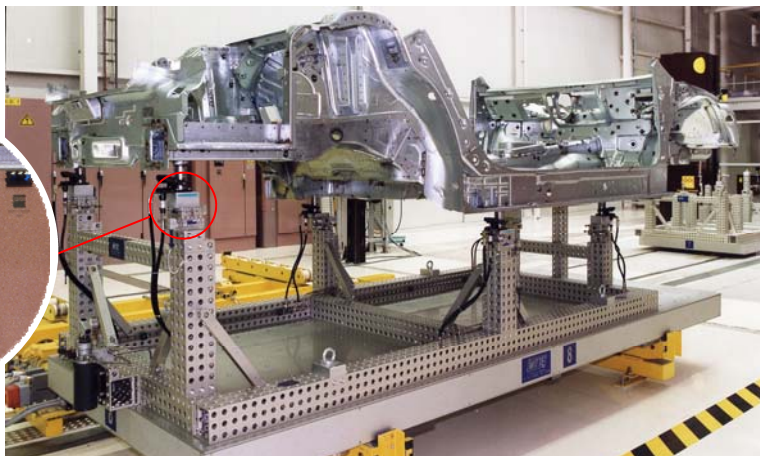

## Witte - Specialists for

## Modular Fixturing Systems

## Subcontracting

## Vacuum Clamping Systems

### Germany

**Witte Barskamp  
GmbH & Co. KG**

Horndorfer Weg 26-28  
D-21354 Bleckede Germany  
Tel.: +49 (0)5854 89-0  
Fax: +49 (0)5854 89-40  
E-Mail: [info@witte-barskamp.de](mailto:info@witte-barskamp.de)  
[www.witte-barskamp.de](http://www.witte-barskamp.de)

### Asia

**Witte Far East Pte Ltd**

1st. Level  
13 Joo Koon Crescent  
SGP-629021  
Singapore  
Tel.: +65-6248 5961  
Fax: +65-6898 4542  
E-Mail: [info@witteasia.com](mailto:info@witteasia.com)  
[www.witteasia.com](http://www.witteasia.com)

### USA & Canada

**Witte America**

120E Market Street  
Suite 455  
Indianapolis, IN 46204  
Tel.: 317-822-7003  
Fax: 317-822-7009  
E-Mail: [info@witteamerica.com](mailto:info@witteamerica.com)  
[www.witteamerica.com](http://www.witteamerica.com)

### Mexico

**Horst Witte de Mexico**

S.A. de C.V., c/o Linco  
Paseo Opera 4 Int 112-2  
Lomas de Angelopolis  
San Andres Cholula,  
Puebla 72830, Mexico  
Phone: +52(222)563-7929  
E-Mail: [info@wittemexico.com](mailto:info@wittemexico.com)  
[www.wittemexico.com](http://www.wittemexico.com)

Witte puts your ideas into practice!



Fixed on precision